

SPT27R3 – SPT27G3 Data Sheet

1. Description

The SPT27 series modules are active RFID (Radio Frequency Identification) transmitters based on the STE proprietary and patented SPX technology. The pulse modulation (PPM) data transmission allows to realize compact modules powered by small lithium batteries able to transmit an ID code plus optional alarms or data commands continuously for many years.

The RF pulse stream generation as well as the Op./mode of the two module versions are programmed ("R1" Software) into a Texas MSP430 microcontroller optimized for ultralow consumption.

Into the "R1" software the transmitted messages repetition rate is factory programmed in 2 seconds (default time), 1 or 6 seconds: a different repetition rate time can be programmed on request.

The transmitter module employs a compact "Loop" magnetic antenna to obtain the max feasible RF e.r.p. (effective radiated power) compatible with the very small PCB dimensions.

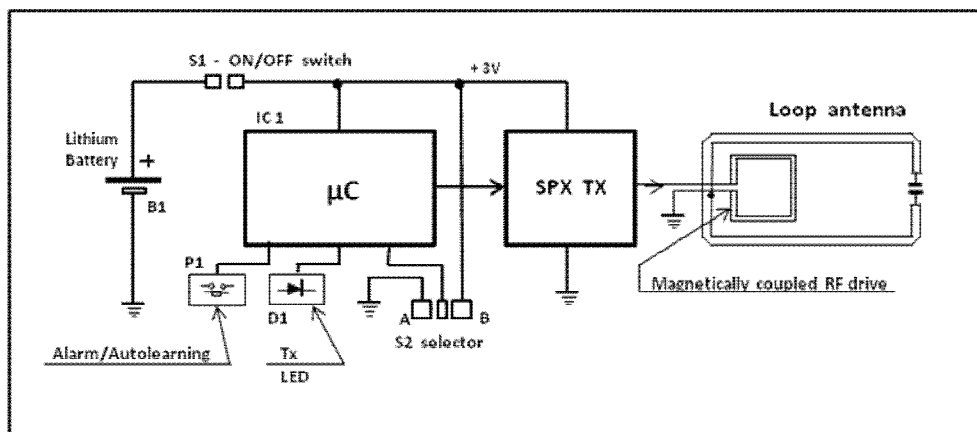

Fig. 1 SPT27R3 - Block Diagram .

2. Transmission protocol and data frame structure ("R1" software).

The data message is packaged into a 6ms transmission time and it is 40 bit long . The message starts with the emission of two "preamble" pulses followed by a 5 bit "Manufacturer / Network" code plus a 22 bit "ID" code . Five bits are then reserved (only in the SPT27R3 version) for the battery tension measure and for an optional "Alarm" or "Command" to be activated by the P1 button (fig. 1) with also the possibility to send an "autolearning" message. The transmission is completed by an 8 bit "Checksum" (fig. 2) .

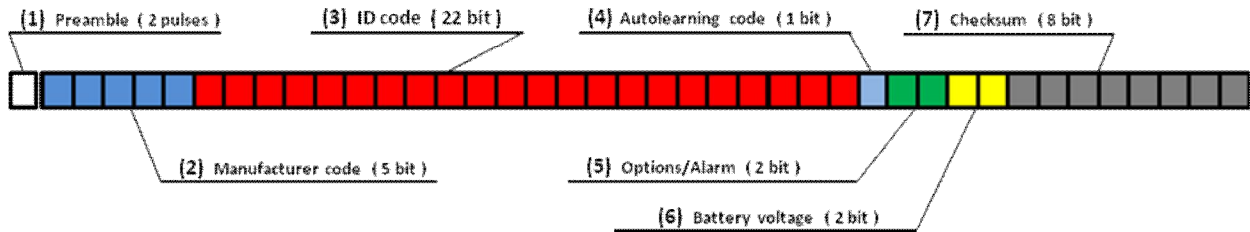

Fig.2 SPT27x3-R1 - RF emission 40bit frame structure .

3. The "SPX" transmitter

Data transmission is performed by the "SPX Tx" (Fig. 1) a simple SAW stabilized RF circuit (EU Patent 07425513.4 / EPO7425513) capable of generating fast and accurate 2µs RF pulses PPM modulated by the IC1 microcontroller .

The RF pulse peak power is relativity high (more than +13 dBm) , but a very low mean averaged e.r.p. and as a consequence a very low mean current consumption.

4. SPT27R3 – SPT27G3 versions

The SPT27R3 microcontroller is a Texas MSP430F2012 and it implements also battery tension measurement . On this version are also mounted a Push Button Switch (P1) plus a Red LED (D1).

The SPT27G3 is an economy version without P1 and D1 and IC1 is an MSP430G2001 "Value Line" microcontroller .

Battery tension measurement and "autolearning" facility are not implemented on this version.

5. RF performance data

PARAMETER		NOTES
Frequency	434.4 MHz	
RF Peak Power (radiated)	-10 dBm	
ERP Power Density (10kHz BW)	-23 dBm/10kHz	
Modulation	PPM	Pulse Position Modulation
Emission -6dB Bandwidth	350 kHz	
Transm. repetition rate	1-2-6 sec	Hardware selectable
Supply voltage	3 V nom.	2.4 V min / 3.6 V max
Current	5 - 3.6 – 1.8 µA	Depending on Tx rep. rate
Operating Temp.	- 40 +85 °C	

6. Lithium Battery and expected life .

The SPT27 modules are designed to be powered by a CR1225 Lithium 3V Battery. To increase the expected life also a CR1632 Battery can be employed (refer to the mechanical dimensions – fig 3).

Expected continuous operation life depends on transmission repetition rate and on battery size (Table 1) .

TX REPETITION RATE	CR1225 (48 mA/h)	CR1632 (125 mA/h)
1 s	1 Year	2,5 Years
2 s	1,5 Years	6 Years
6 s	3 Years	> 10 Years

Table 1 - Expected life

7. Mechanical dimensions

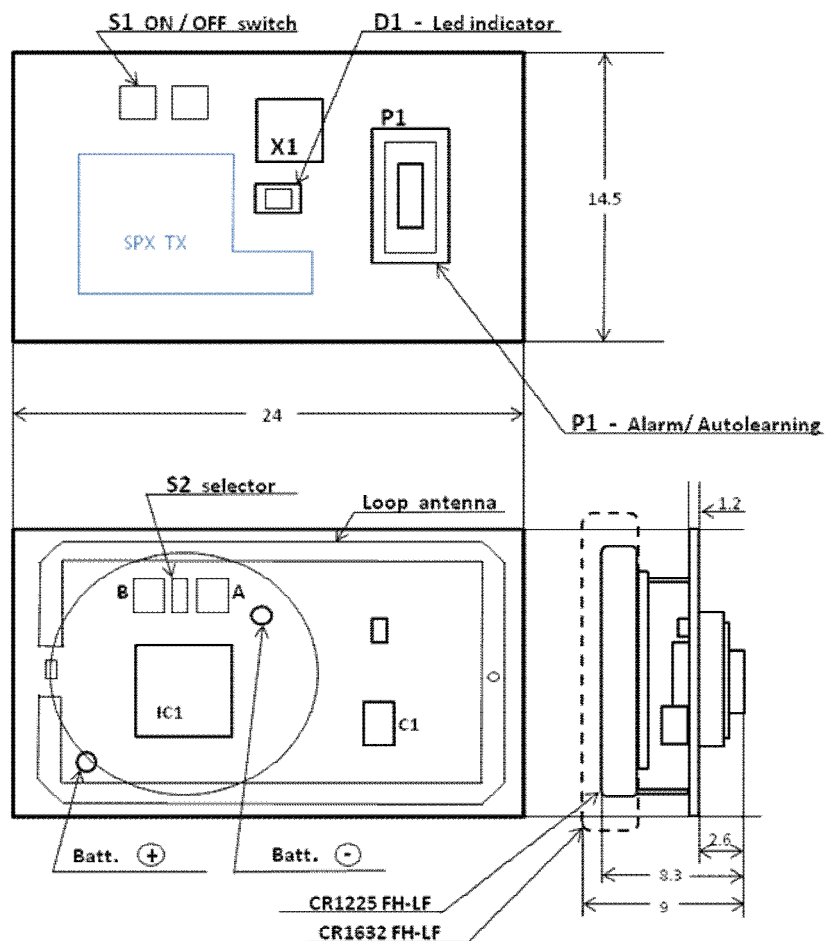

Fig. 3 Mechanical dimensions

S2 Selector - Transmission messages time T1

- 1) Short in "A" : T1 = 1s
- 2) Short in "B" : T1 = 6s
- 3) S2 "Open" : T1 = 2s (Default condition)

8. Legal Considerations

The SPT27R3 and the SPT27G3 are conformed to the EN 300 220 (v 2.2.1) Harmonized Standards and to the ERC/REC 70-03 recommendations (Annex 1 – band f1) and also to the FCC part 15 Rules and Regulations .

A typical radiated RF spectrum of a module mounted in a small plastic box is depicted in Fig. 4 : the required bandwidth measured with a resolution of 30 kHz is below the required -20 dBc .